

Velocity prediction examples with « SA-VPP Sailboat 1.0 »

Jean-François Masset – October 2020

jfcmasset@outlook.fr

« SA-VPP Sailboat 1.0 » spreadsheet application is here illustrated through 4 examples :

- **V1 classic modern sailboat** (the reference boat in « Gene-Hull Sailboat 3.1 »)
- **S30**, inspired by S30 / Knud Reimers
- **Blue Water 39**, inspired by Corbin 39 / Robert Dufour - Marius Corbin
- **F3**, inspired by Beneteau Figaro III / VPLP

Boat V1 modern classic daysailer

Hull and appendages

Loa 10,30 m ; Lwl 8,00 m ; B 2,60 m ; Draft 1,75 m ; Light weight : 2652 kg ; Keel-bulb 1092 kg

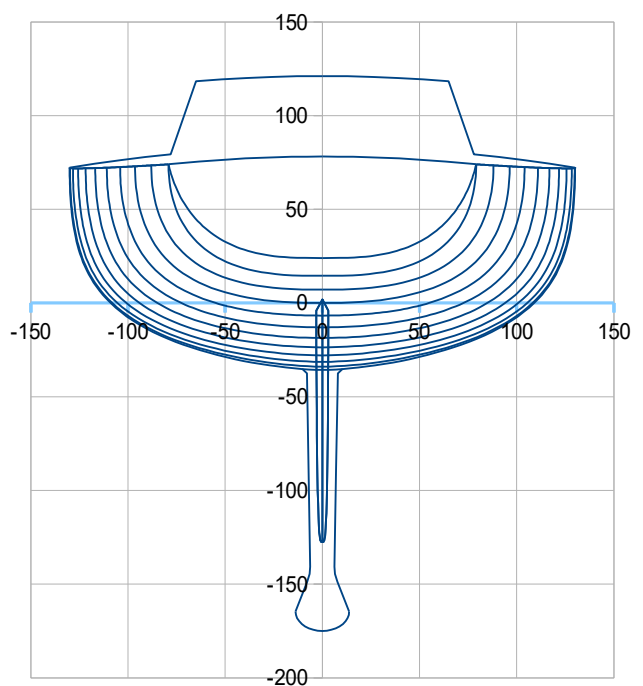
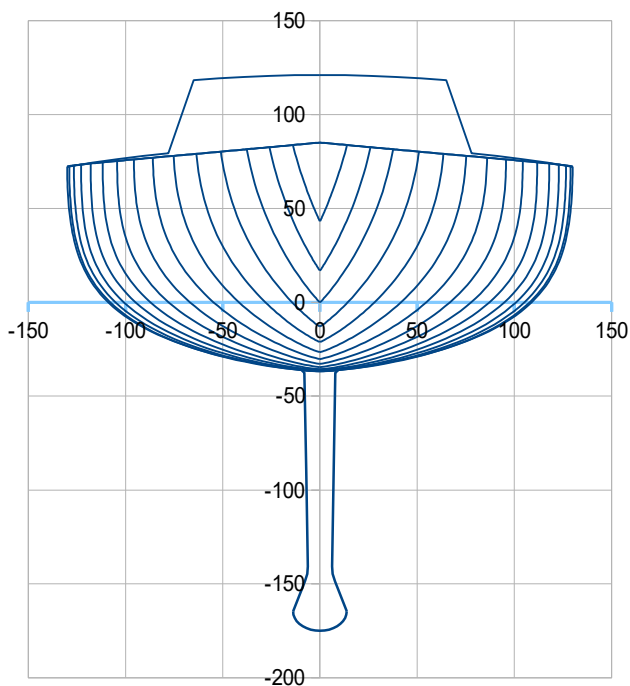
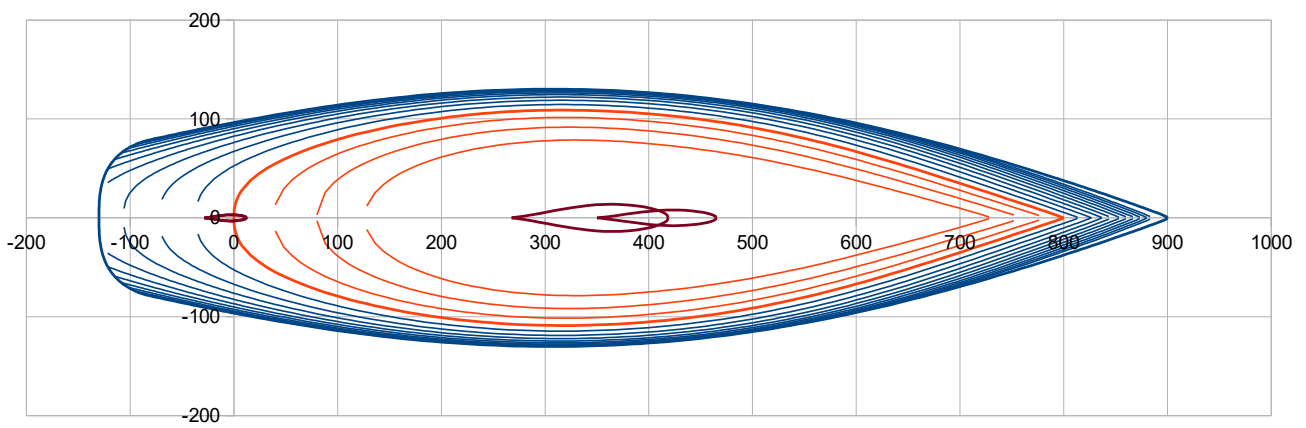
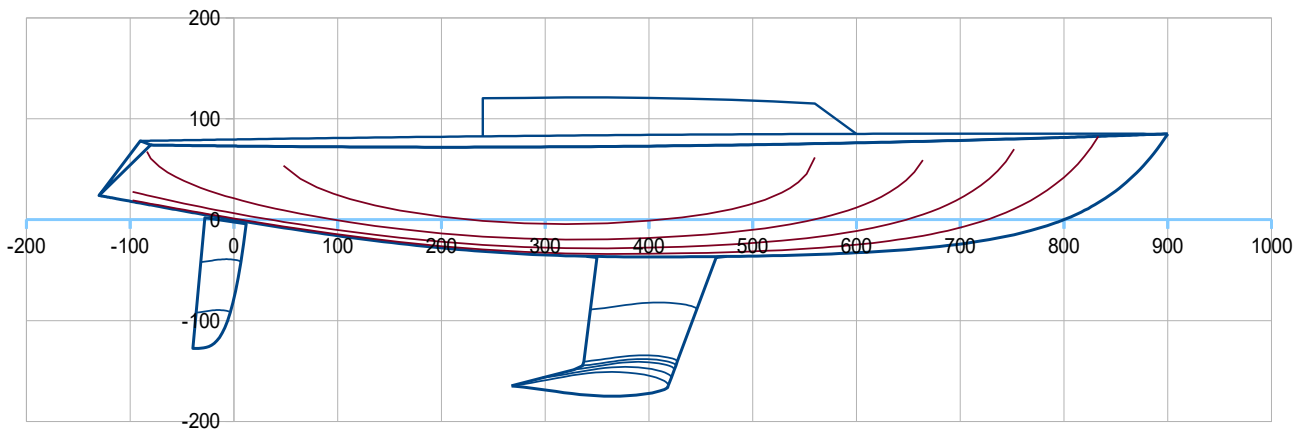

Sailplan

SA (m2)	ZCE (m)	Zdeck (m)	Zmast (m)	Main (m2)	Spi (m2)	ZCE spi (m)
43,61	5,37	0,85	13,23	24,09	68,34	6,35

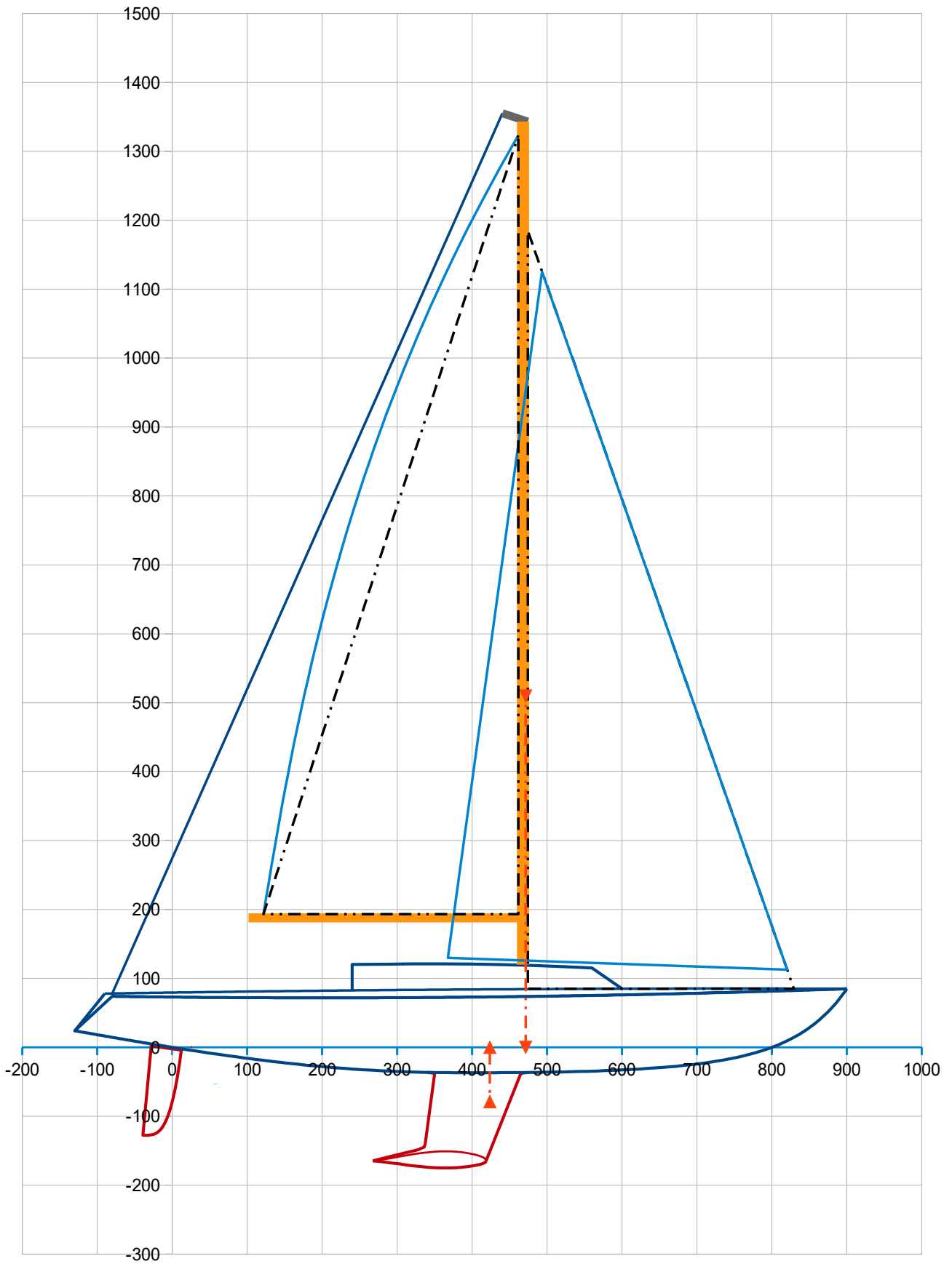

SA-VPP input data for V1 with a loading of 300 kg (crew sit windward) :

For SA-VPP, hull body data with loading and at equilibrium upright (Heel = 0°)						From the Sailplan sheet :								
Lwl (m)	Bwl (m)	Tc (m)	Bmax (m)	Cp hull	LCB hull(%)	Sf (m2)	SA (m2)	ZCE (m)	Zdeck (m)	Zmast (m)	Main (m2)	Spi (m2)	ZCE spi (m)	Reef
8,24	2,23	0,39	2,60	0,55	46,79	12,86	43,61	5,37	0,85	13,23	24,09	68,34	6,35	1,00
Keel wing			Keel bulb (if no bulb, put Vol. = 0 and Sw = 0)				Rudder			Displacement and draft at design load				
Vol. (m3)	Sw (m2)	Chord (m)	Vol. (m3)	Sw (m2)	L (m)	D (m)	Vol. (m3)	Sw (m2)	Chord (m)	Disp. (kg)	Draft (m)			
0,09764	2,37	1,15	0,05190	1,30	1,55	0,28	0,01486	0,91	0,40	2952	1,77			
Righting Moment RM (kN.m)			Wetted surface Sw (m2)											
RM0°	RM20°	RM30°	Sw0°	Sw20°	Sw30°									
2,953	11,341	13,790	18,53	17,79	17,31									

>>> Output

SA-VPP : Speed results

Red : Upwind ; Blue : reaching twa 90° ; Green : downwind with spi twa 135°

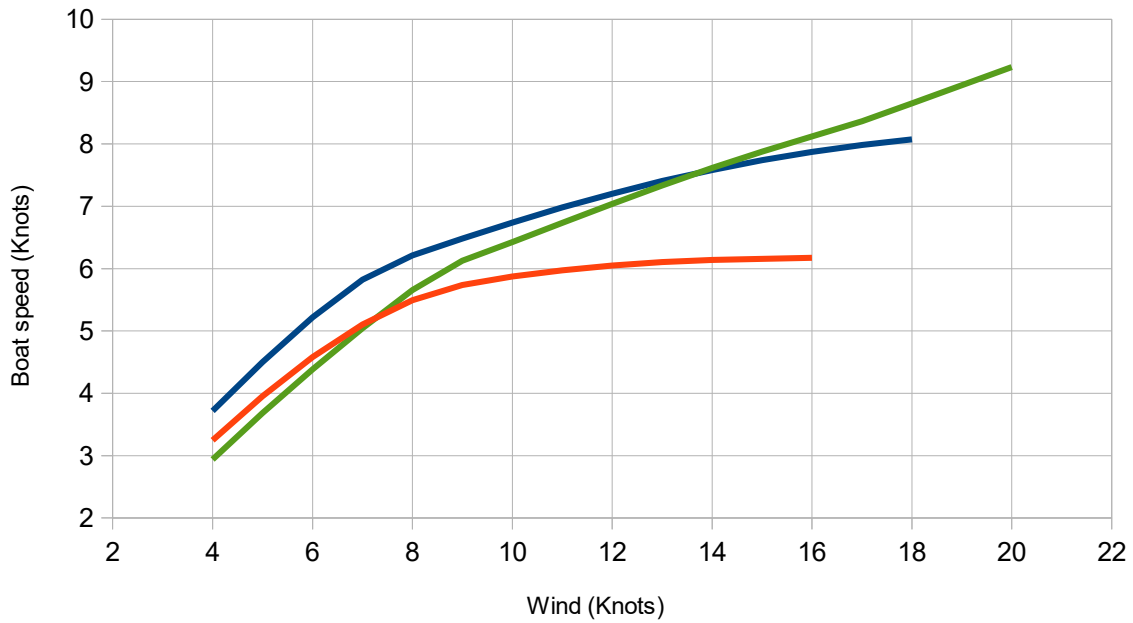

SA-VPP : Flat optimum when upwind

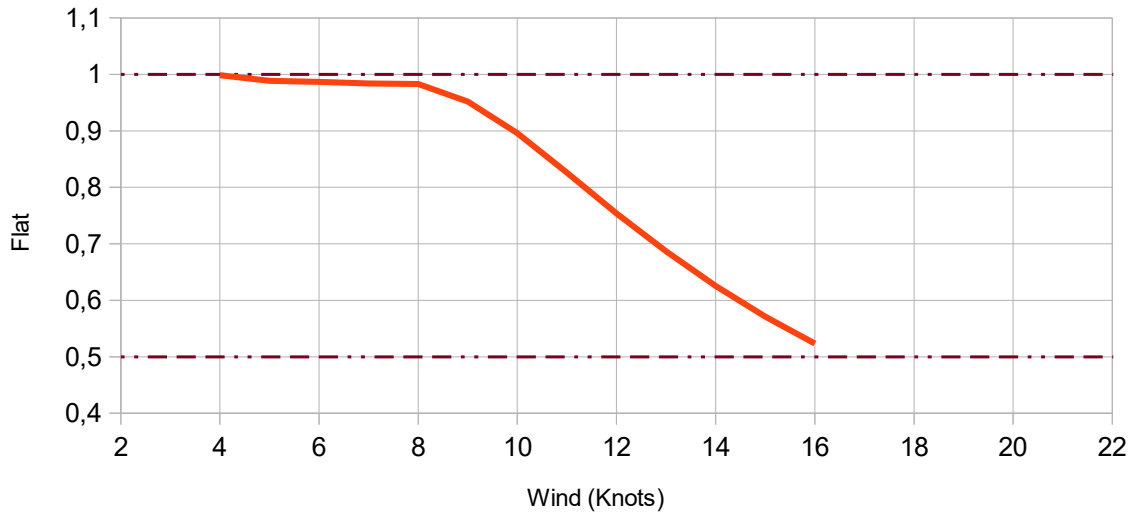

SA-VPP : Heel results

Red : Upwind ; Blue : reaching twa 90° ; Green : downwind with spi twa 135°

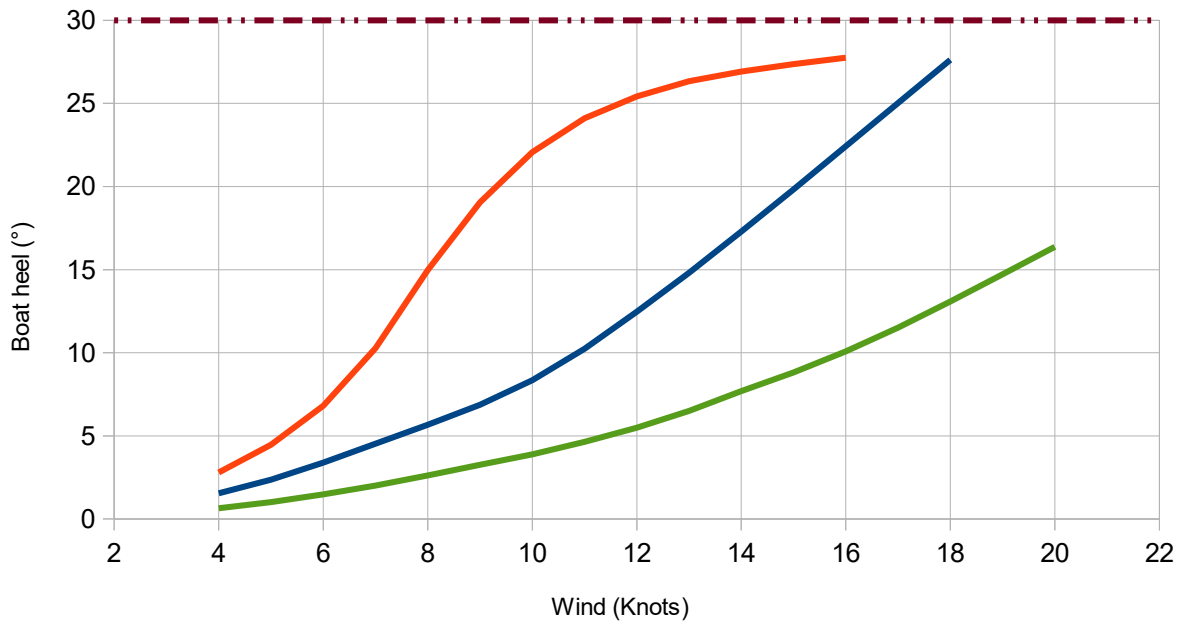

SA-VPP : Righting Moment RM versus heel angle

Black points : RM input values ; Blue : RM programmed function
Red points : SA-VPP output when upwind

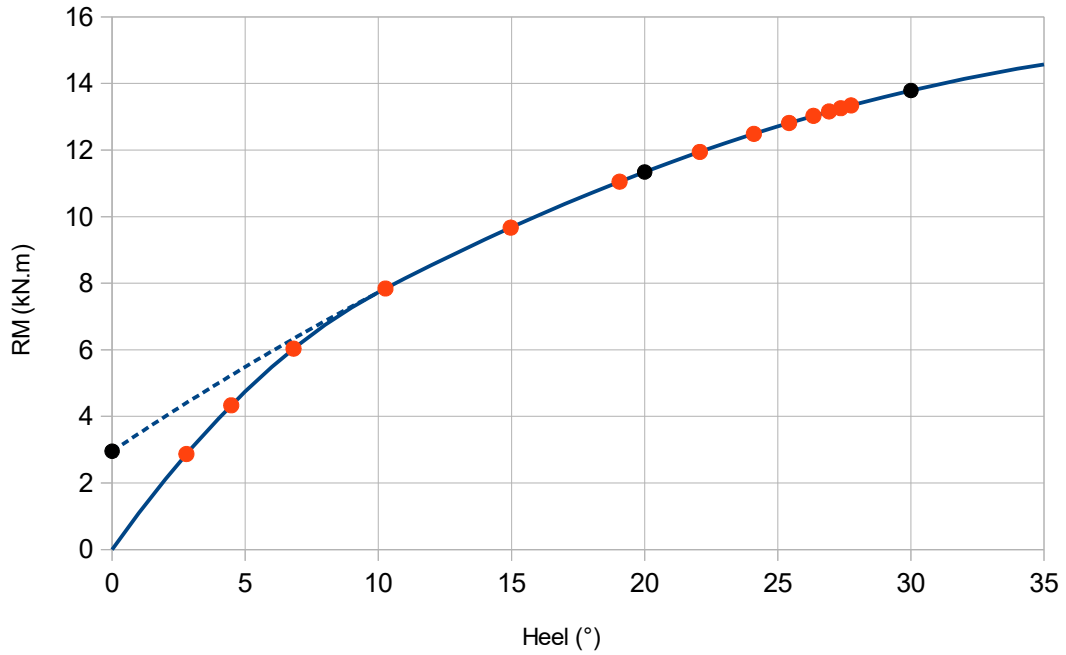

SA-VPP : Drag versus boat speed

Red : Upwind ; Blue : reaching twa 90° ; Green : downwind with spi twa 135°

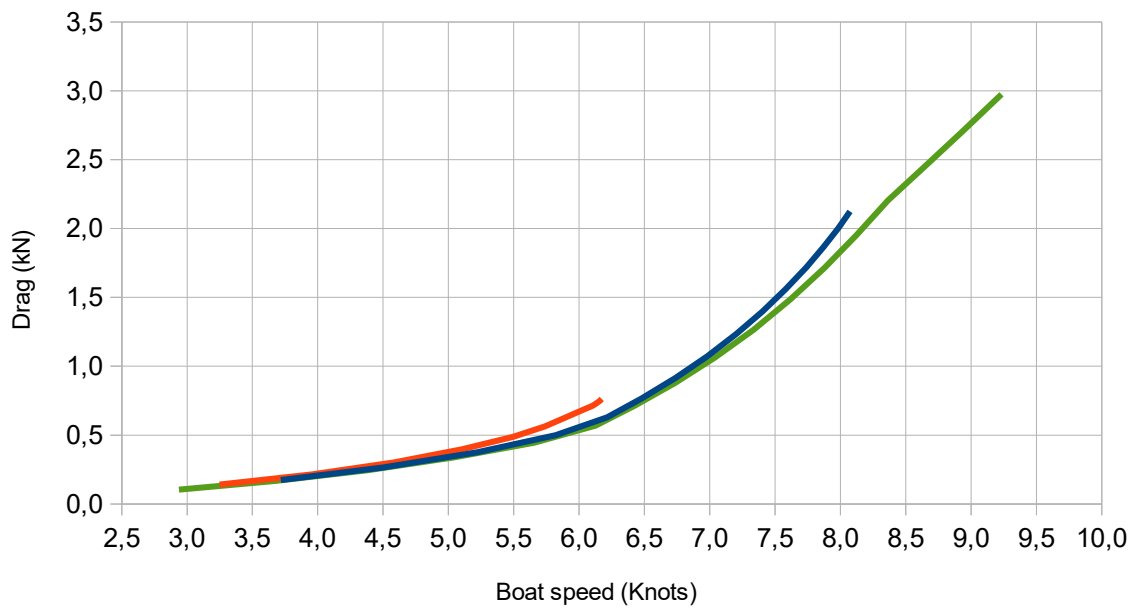

S30, inspired by the S30 / Knud Reimers

Loa 12,50 m ; Lwl 9,9 m ; B 2,50 m ; Draft 1,55 m ; Light weight : 4229 kg ; Ballast : 1511 kg

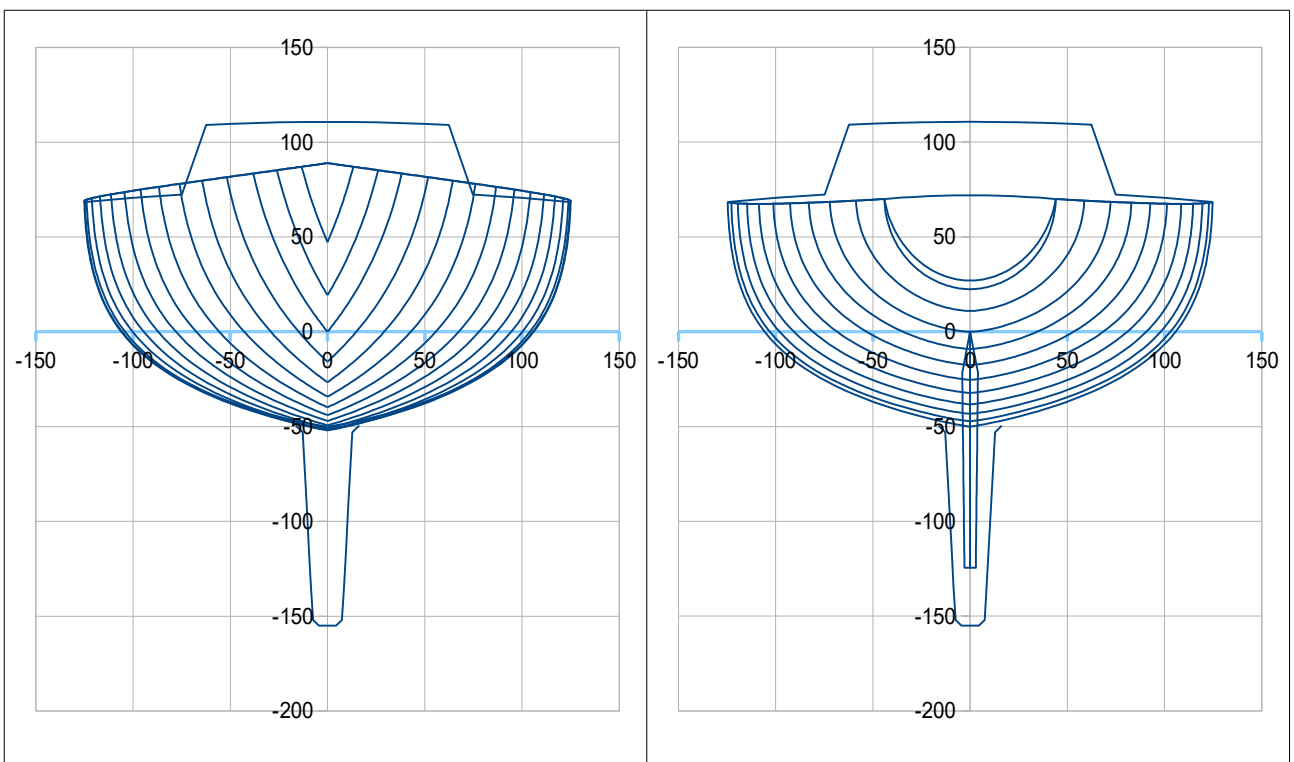
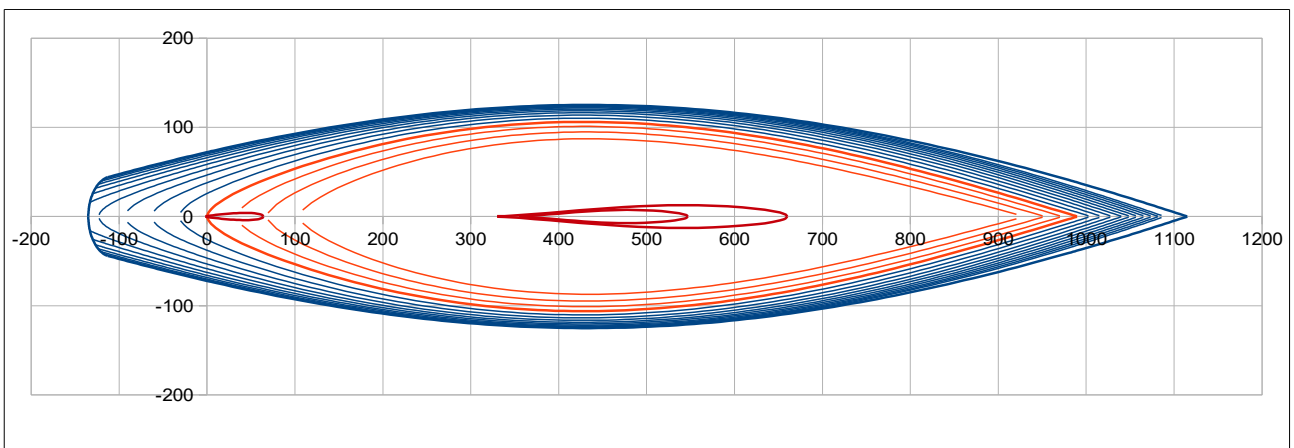
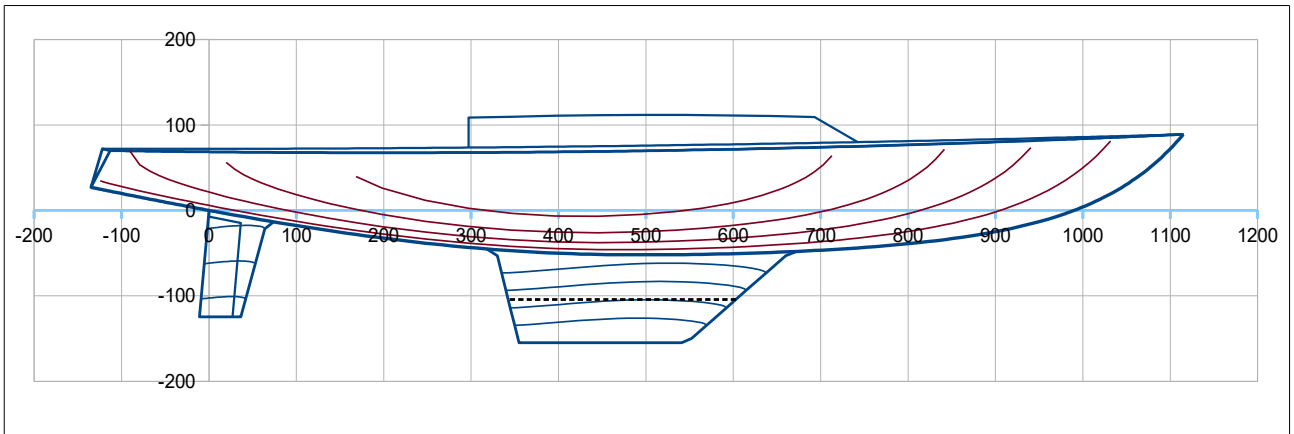

Sailplan :

SA (m2)	ZCE (m)	Zdeck (m)	Zmast (m)	Main (m2)	Spi (m2)	ZCE spi (m)
42,69	5,26	0,87	13,18	24,58	63,37	6,30

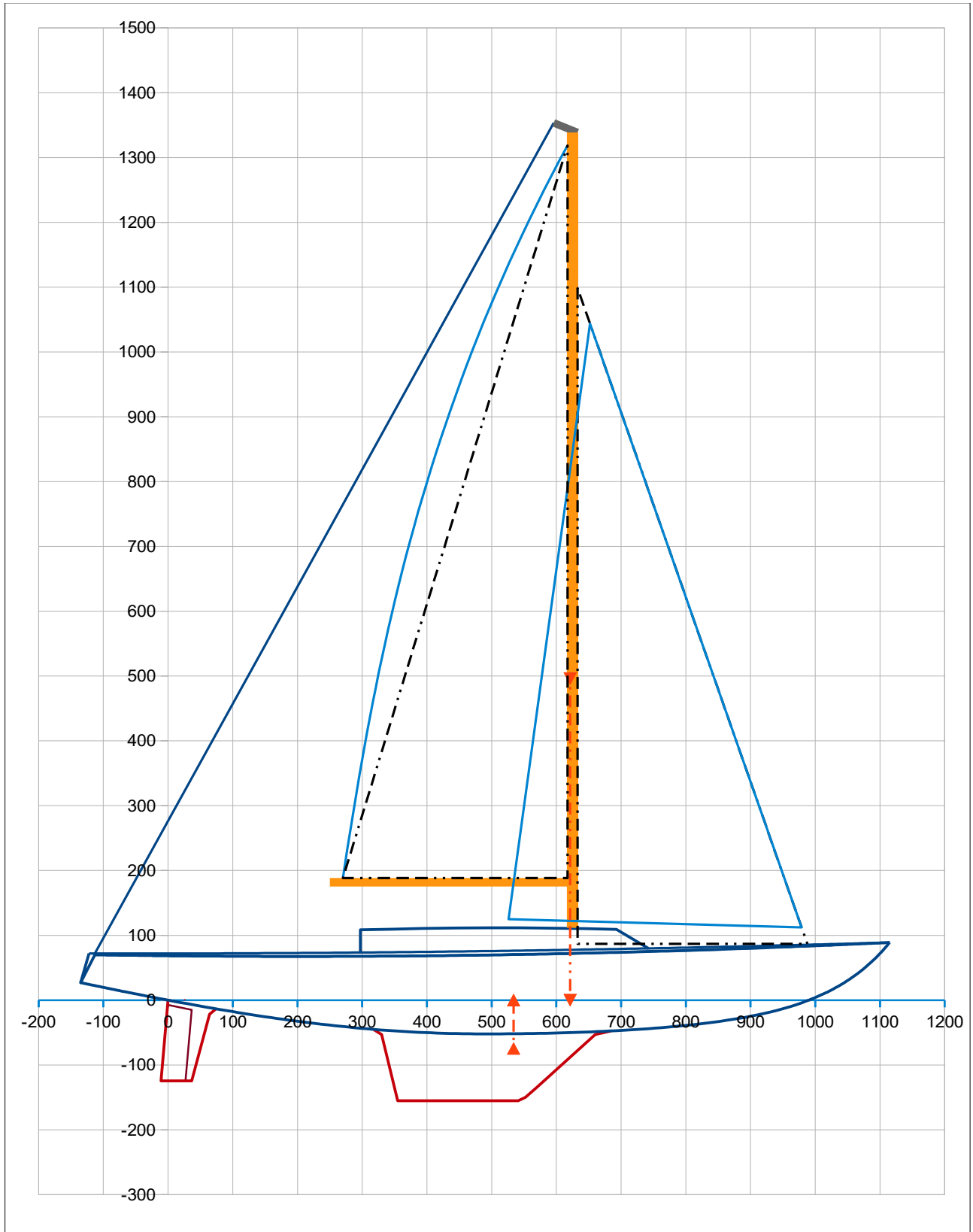

SA-VPP input data for S30 with a loading of 300 kg (crew sit windward) :

For SA-VPP, hull body data with loading and at equilibrium upright (Heel = 0°)							From the Sailplan sheet :								
Lwl (m)	Bwl (m)	Tc (m)	Bmax (m)	Cp hull	LCB hull(%)	Sf (m2)	SA (m2)	ZCE (m)	Zdeck (m)	Zmast (m)	Main (m2)	Spi (m2)	ZCE spi (m)	Reef	
10,13	2,16	0,54	2,50	0,527	48,31	14,65	42,69	5,26	0,87	13,18	24,58	63,37	6,30	1,00	
Keel wing			Keel bulb (if no bulb, put Vol. = 0 and Sw = 0)				Rudder			Displacement and draft at design load					
Vol. (m3)	Sw (m2)	Chord (m)	Vol. (m3)	Sw (m2)	L (m)	D (m)	Vol. (m3)	Sw (m2)	Chord (m)	Disp. (kg)	Draft (m)				
0,36212	5,54	3,30	0,00000	0,00	0,00	0,00	0,03271	1,36	0,64	4529	1,57				
Righting Moment RM (kN.m)			Wetted surface Sw (m2)												
RM0°	RM20°	RM30°	Sw0°	Sw20°	Sw30°										
2,956	10,865	13,938	23,75	23,42	23,29										

Output :

SA-VPP : Speed results

Red : Upwind ; Blue : reaching twa 90° ; Green : downwind with spi twa 135°

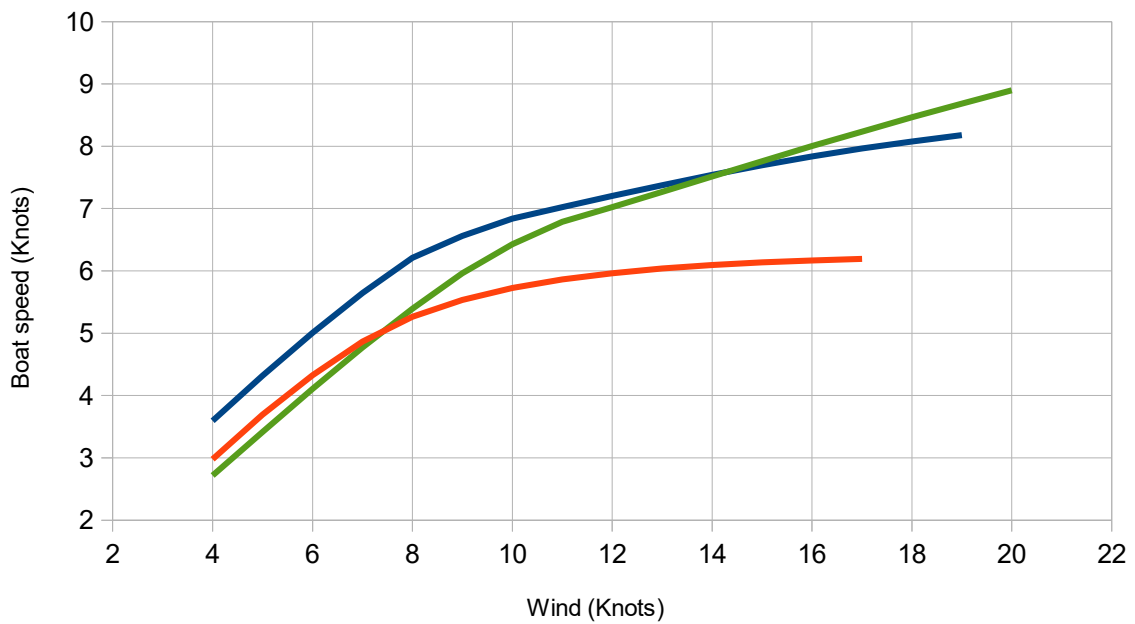

SA-VPP : Flat optimum when upwind

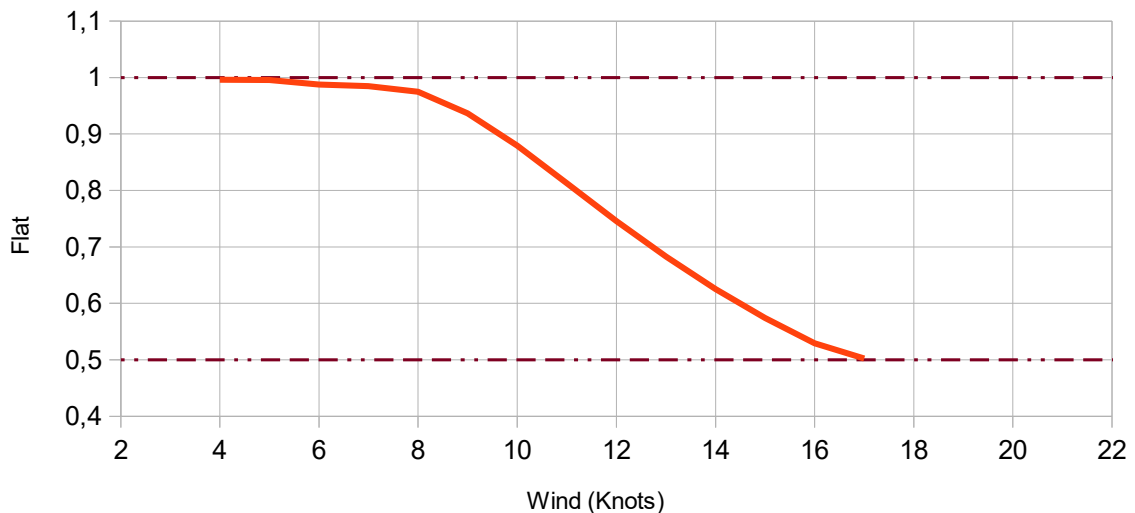

SA-VPP : Heel results

Red : Upwind ; Blue : reaching twa 90° ; Green : downwind with spi twa 135°

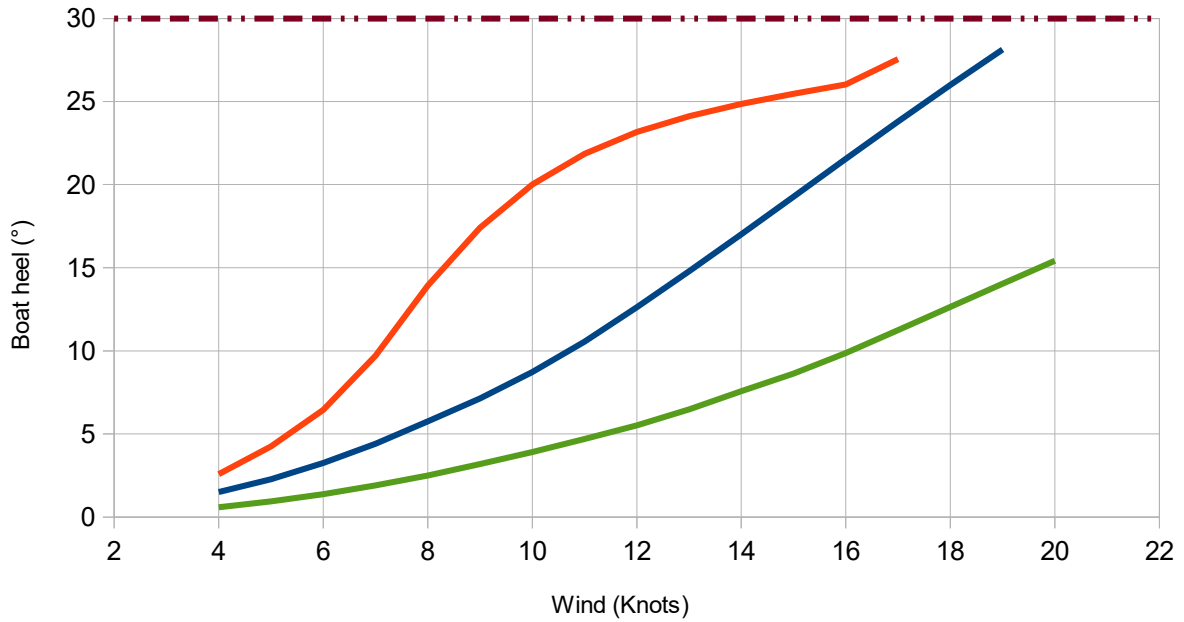

SA-VPP : Righting Moment RM versus heel angle

Black points : RM input values ; Blue : RM programmed function
Red points : SA-VPP output when upwind

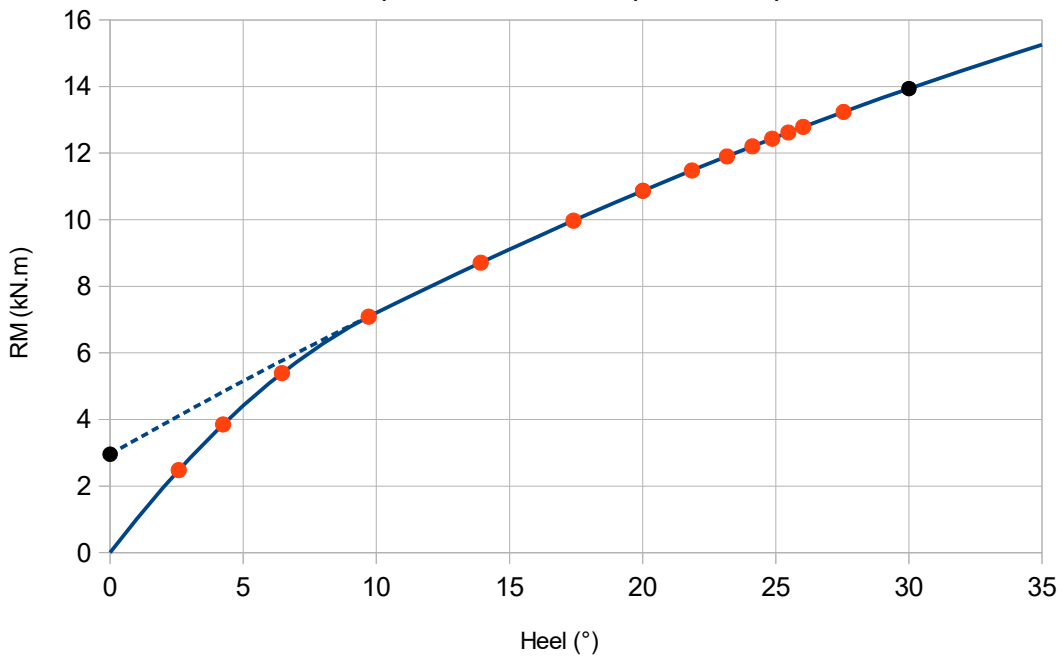

SA-VPP : Drag versus boat speed

Red : Upwind ; Blue : reaching twa 90° ; Green : downwind with spi twa 135°

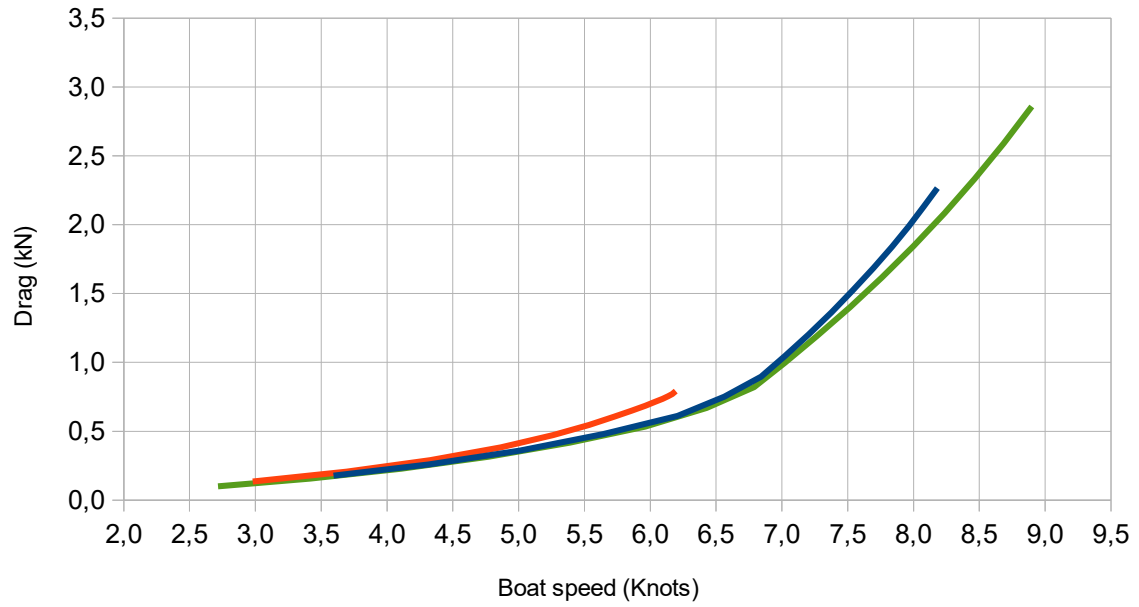

Blue Water 39, inspired by Corbin 39 / Robert Dufour – Marius Corbin

Loa 11,46 m ; Lwl 9,72 m ; B 3,71 m ; Draft 1,68 m ; Light weight : 10741 kg ; Ballast : 4073 kg

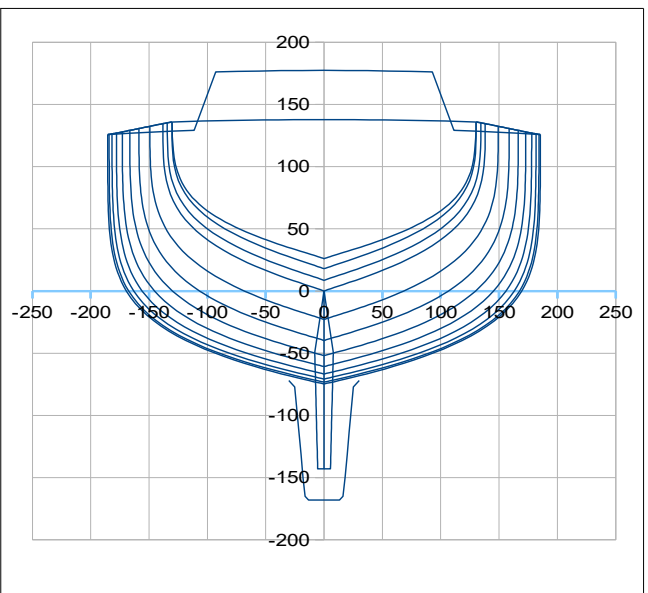
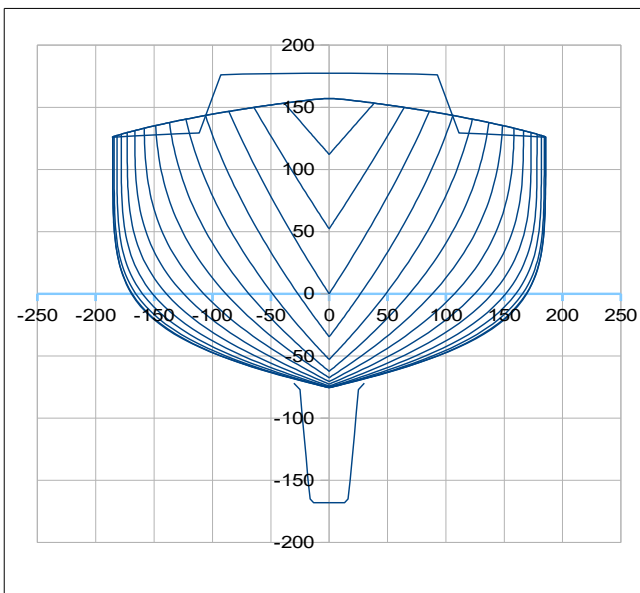
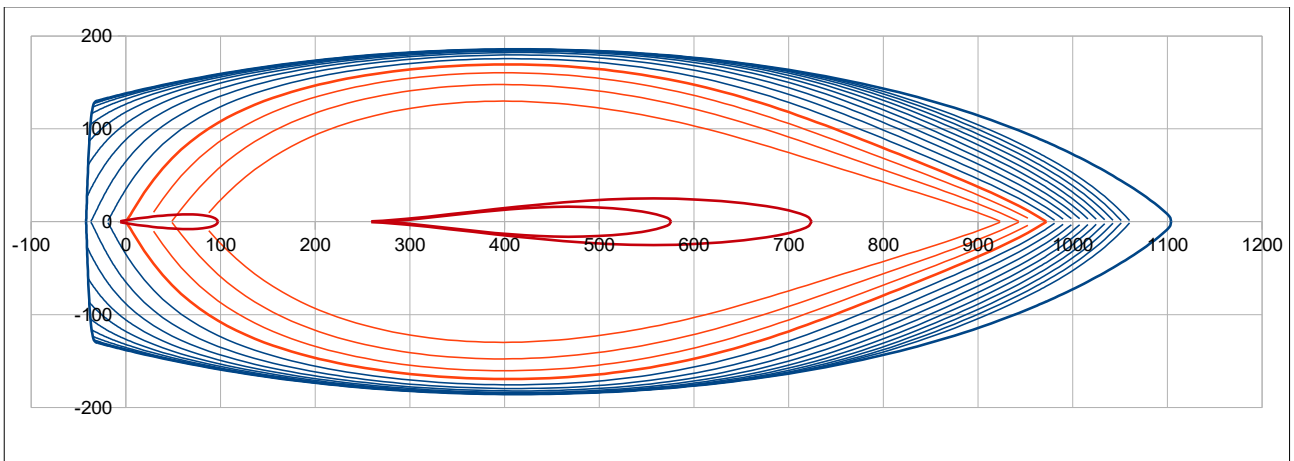
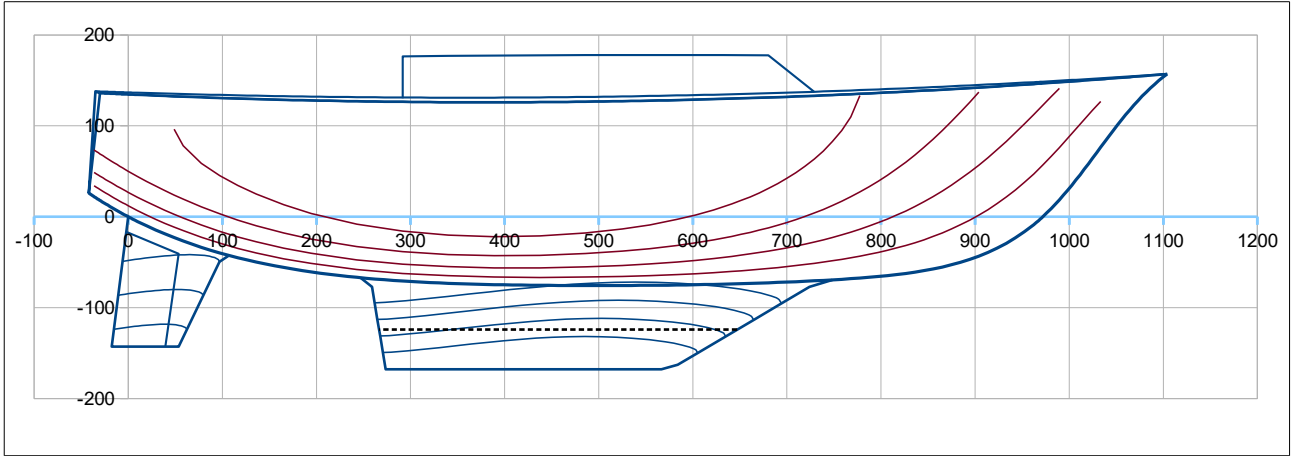

Sailplan :

SA (m2)	ZCE (m)	Zdeck (m)	Zmast (m)	Main (m2)	Spi (m2)	ZCE spi (m)
85,78	7,25	1,52	16,48	45,02	95,61	8,26

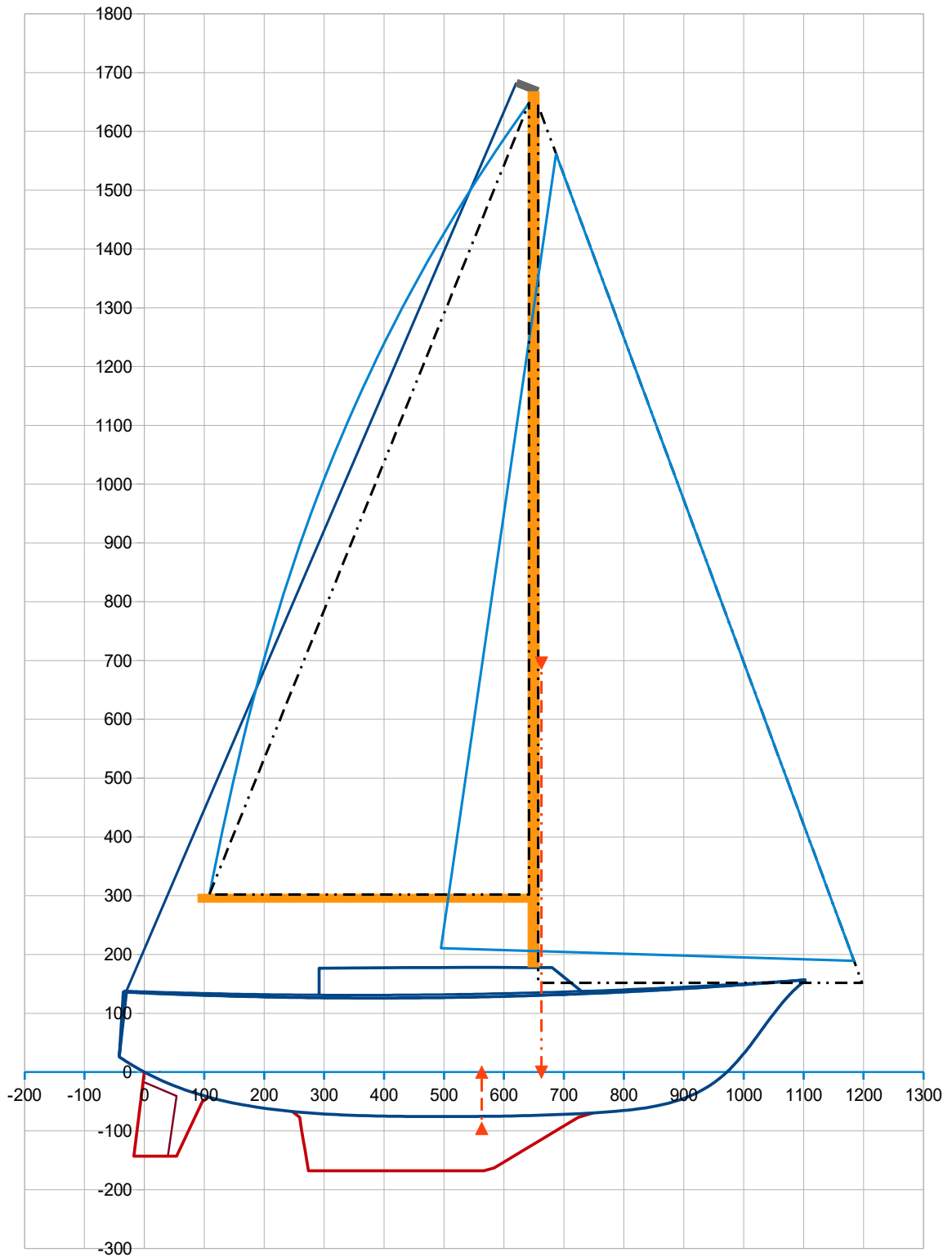

SA-VPP input data for Blue Water 39 with full loading displacement of 14000 kg

For SA-VPP, hull body data with loading and at equilibrium upright (Heel = 0°)							From the Sailplan sheet :								
Lwl (m)	Bwl (m)	Tc (m)	Bmax (m)	Cp hull	LCB hull(%)	Sf (m2)	SA (m2)	ZCE (m)	Zdeck (m)	Zmast (m)	Main (m2)	Spi (m2)	ZCE spi (m)	Reef	
10,04	3,53	0,89	3,71	0,596	47,04	24,28	85,78	7,25	1,52	16,48	45,02	95,61	8,26	1,00	
Keel wing				Keel bulb (if no bulb, put Vol. = 0 and Sw = 0)			Rudder			Displacement and draft at design load					
Vol. (m3)	Sw (m2)	Chord (m)	Vol. (m3)	Sw (m2)	L (m)	D (m)	Vol. (m3)	Sw (m2)	Chord (m)	Disp. (kg)	Draft (m)				
0,96865	7,69	4,65	0,00000	0,00	0,00	0,00	0,10547	2,22	0,97	14000	1,75				
Righting Moment RM (kN.m)				Wetted surface Sw (m2)											
RM0	RM15	RM30		Sw0	Sw15	Sw30									
-0,077	46,468	63,894		39,49	39,23	39,04									

Output :

SA-VPP : Speed results

Red : Upwind ; Blue : reaching twa 90° ; Green : downwind with spi twa 135°

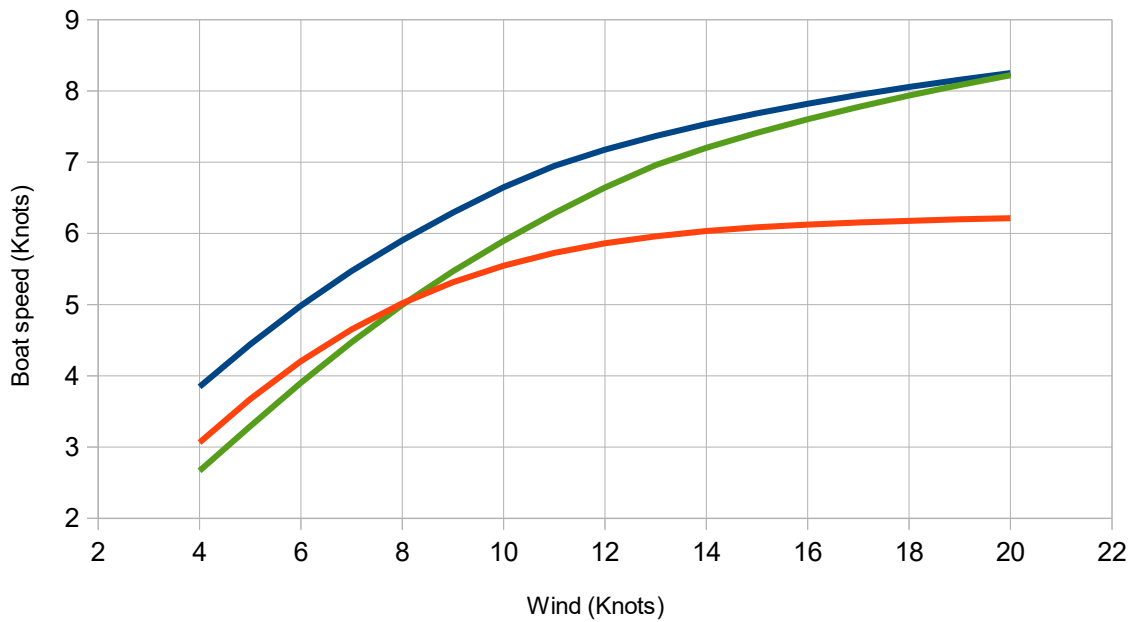

SA-VPP : Flat optimum when upwind

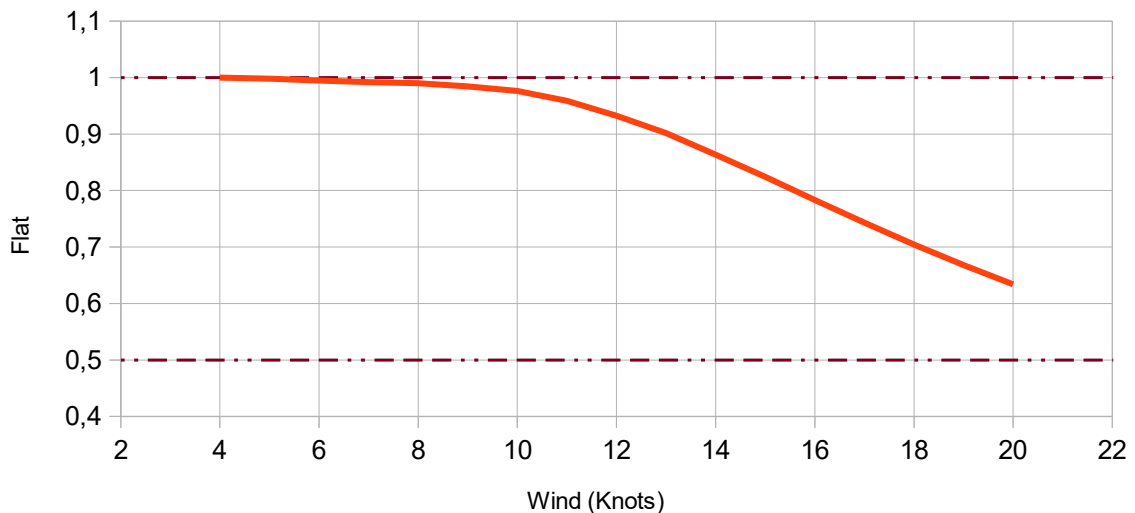

SA-VPP : Heel results

Red : Upwind ; Blue : reaching twa 90° ; Green : downwind with spi twa 135°

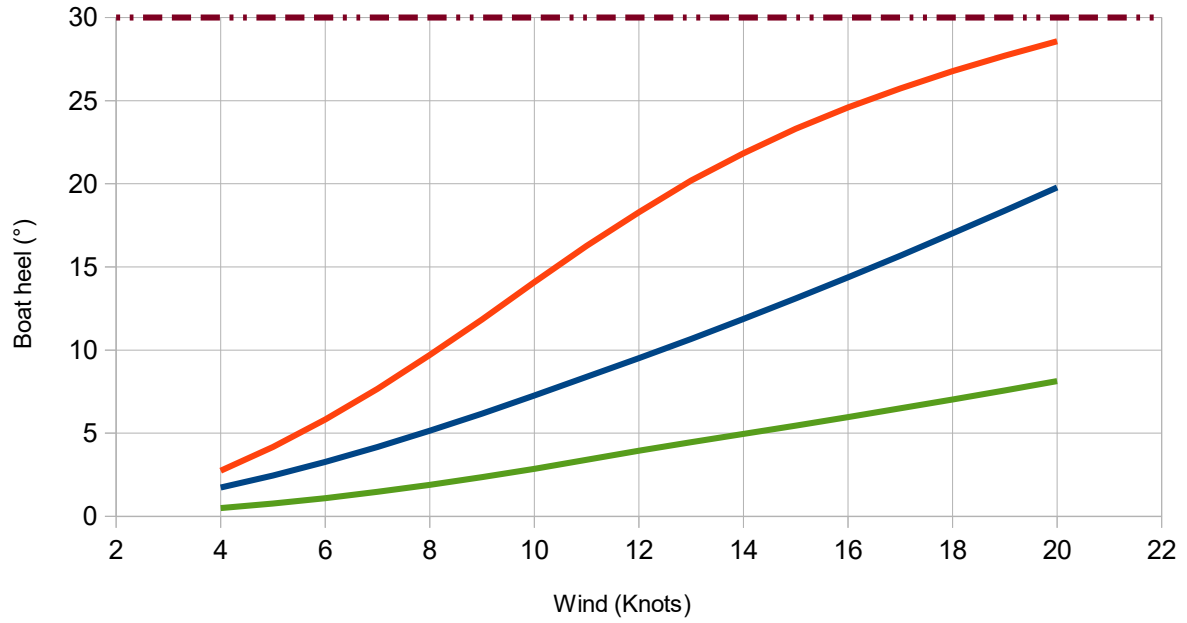

SA-VPP : Righting Moment RM versus heel angle

Black points : RM input values ; Blue : RM programmed function
Red points : SA-VPP output when upwind

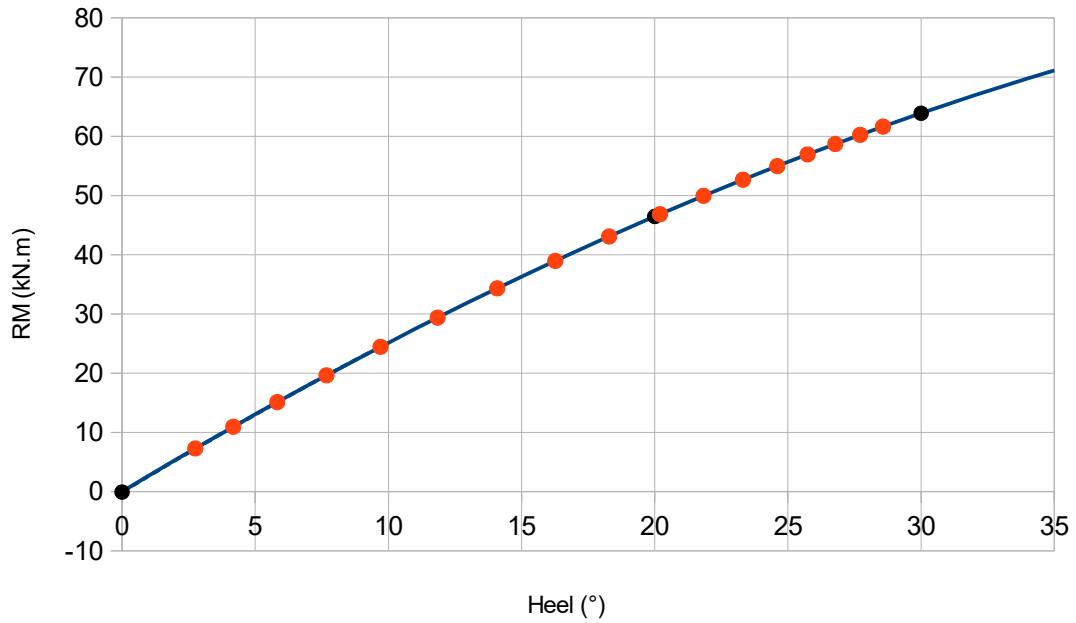

SA-VPP : Drag versus boat speed

Red : Upwind ; Blue : reaching twa 90° ; Green : downwind with spi twa 135°

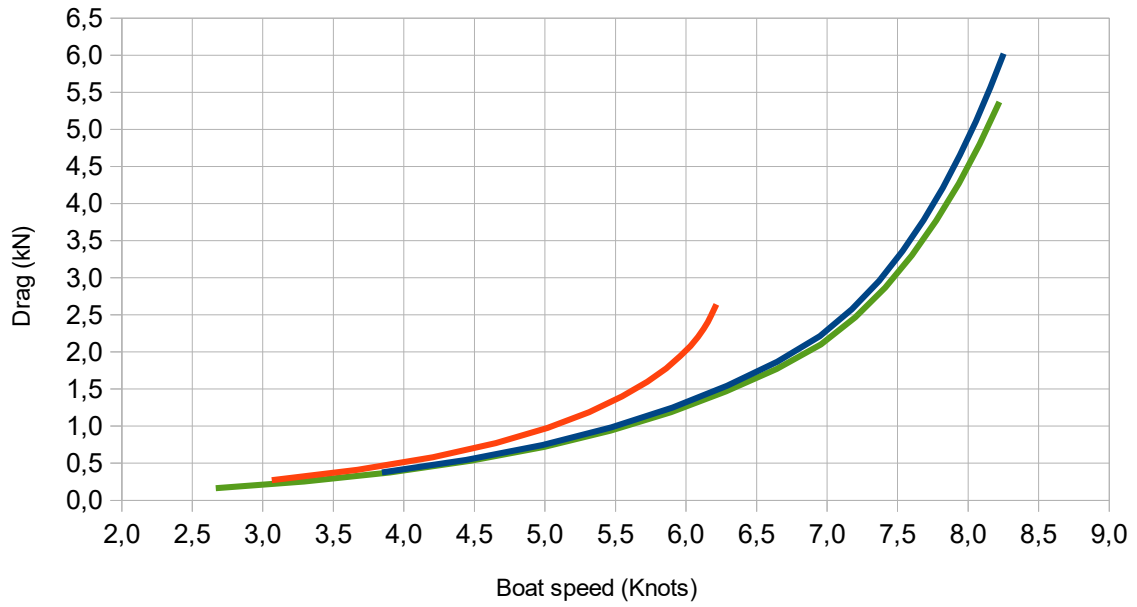

F3, inspired by Beneteau Figaro III / VPLP

Loa 9,75 m ; Lwl 9,40 m ; B 3,47 m ; Draft 2,50 m ; Light weight : 3257 kg ; Ballast : 1243 kg

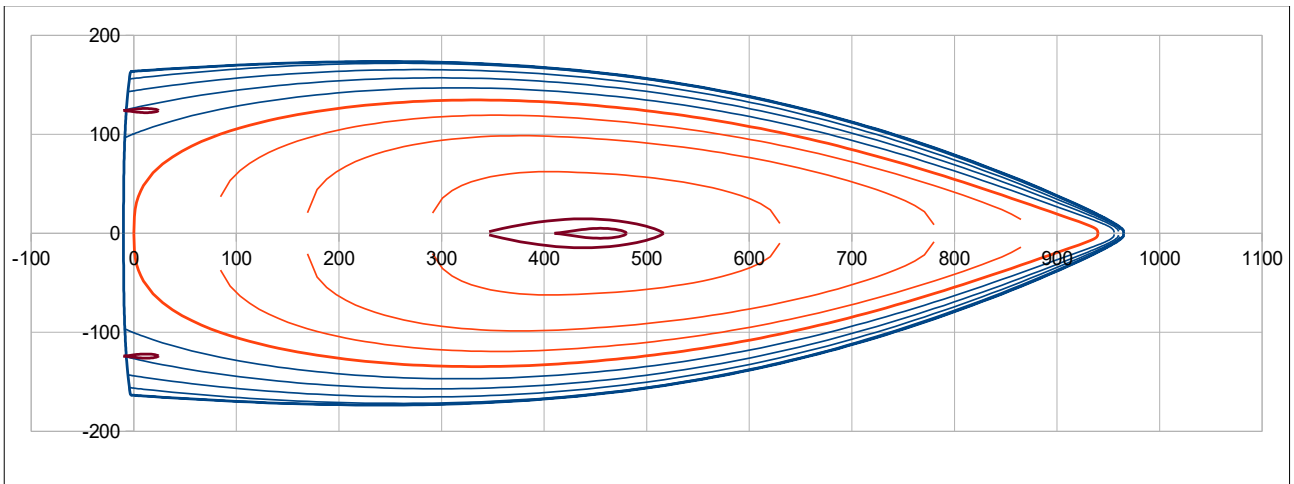
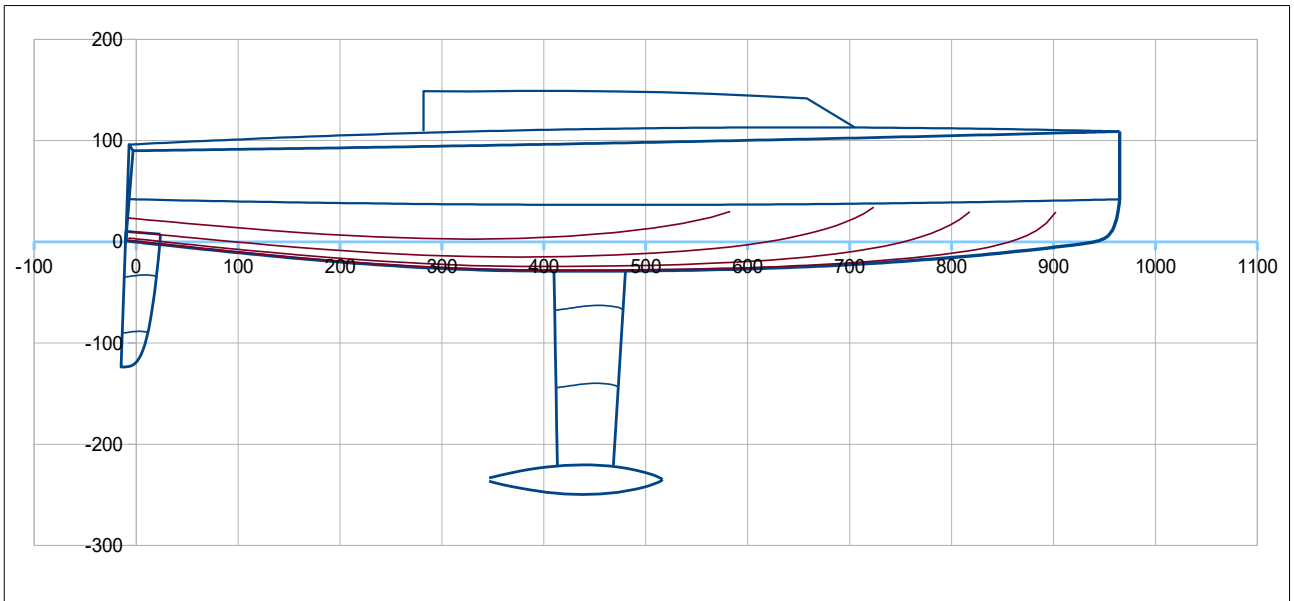

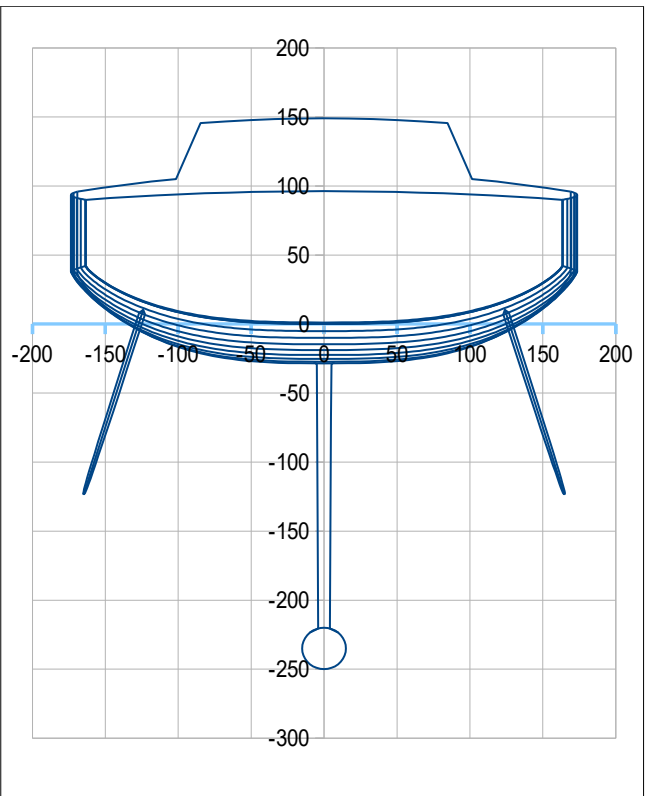
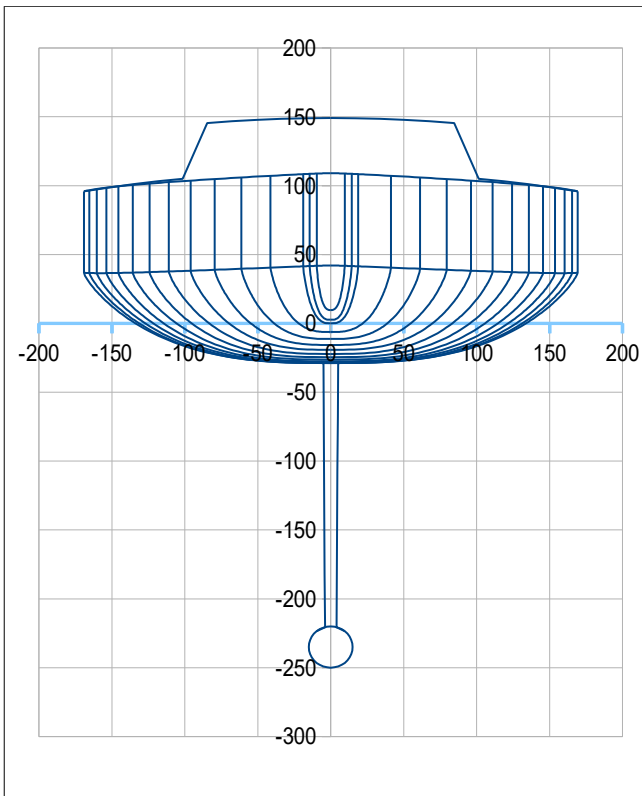

Sailplan :

SA (m2)	ZCE (m)	Zdeck (m)	Zmast (m)	Main (m2)	Spi (m2)	ZCE spi (m)
57,72	6,02	1,09	14,48	30,84	94,06	7,00

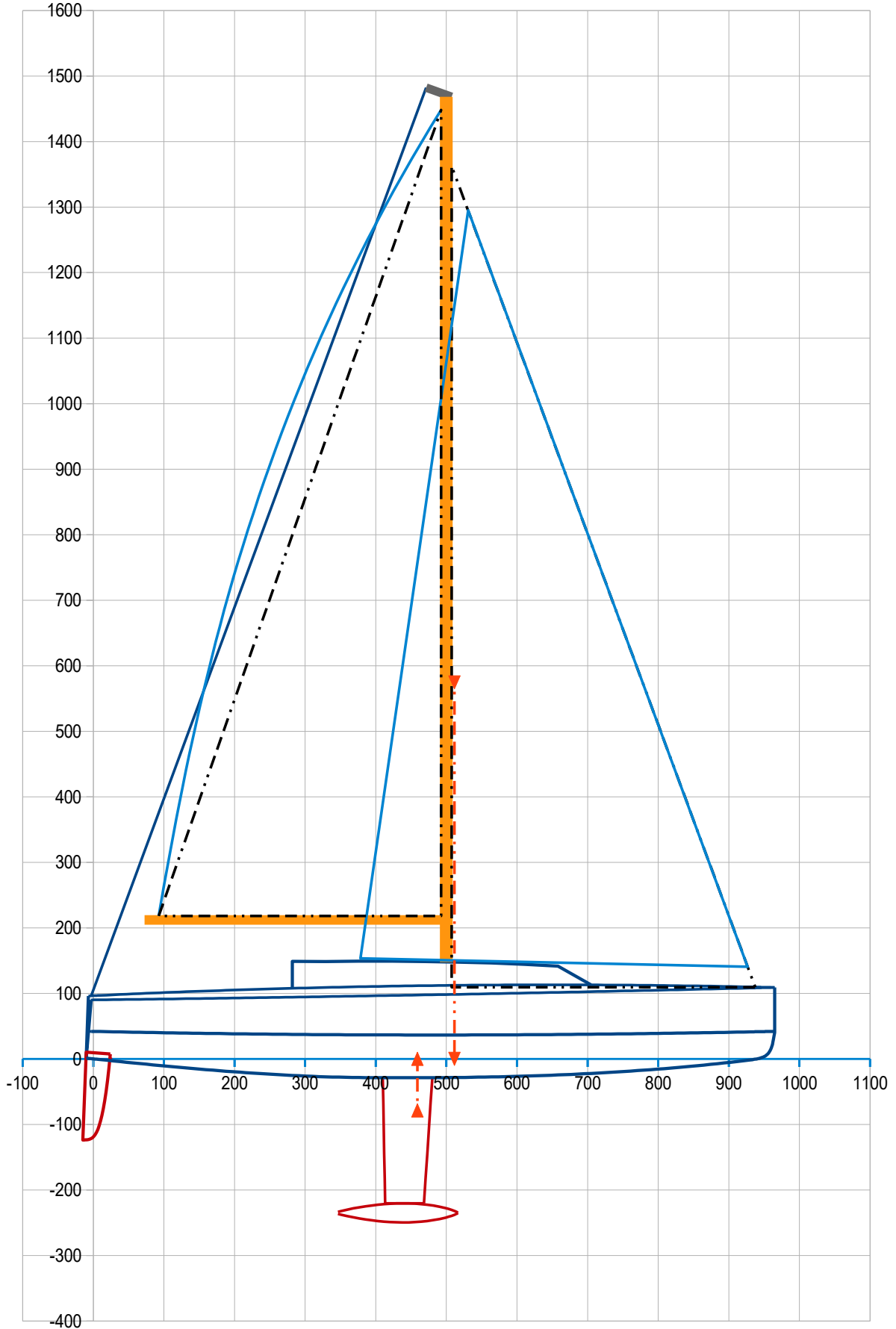

SA-VPP input data for F3 with a loading of 160 kg (crew sit windward) :

For SA-VPP, hull body data with loading and at equilibrium upright (Heel = 0°)							From the Sailplan sheet :							
Lwl (m)	Bwl (m)	Tc (m)	Bmax (m)	Cp hull	LCB hull(%)	Sf (m2)	SA (m2)	ZCE (m)	Zdeck (m)	Zmast (m)	Main (m2)	Spi (m2)	ZCE spi (m)	Reef
9,31	2,73	0,29	3,47	0,571	45,54	18,78	57,72	6,02	1,09	14,48	30,84	94,06	7,00	1,00
Keel wing			Keel bulb (if no bulb, put Vol. = 0 and Sw = 0)				Rudder		Displacement and draft at design load					
Vol. (m3)	Sw (m2)	Chord (m)	Vol. (m3)	Sw (m2)	L (m)	D (m)	Vol. (m3)	Sw (m2)	Chord (m)	Disp. (kg)	Draft (m)			
0,06993	2,44	0,70	0,06451	1,07	1,70	0,30	0,01731	1,60	0,34	3417	2,51			
Righting Moment RM (kN.m)			Wetted surface Sw (m2)											
RM0°	RM20°	RM30°	Sw0°	Sw20°	Sw30°									
1,972	20,909	24,490	24,53	21,42	19,58									

Output :

SA-VPP : Speed results

Red : Upwind ; Blue : reaching twa 90° ; Green : downwind with spi twa 135°

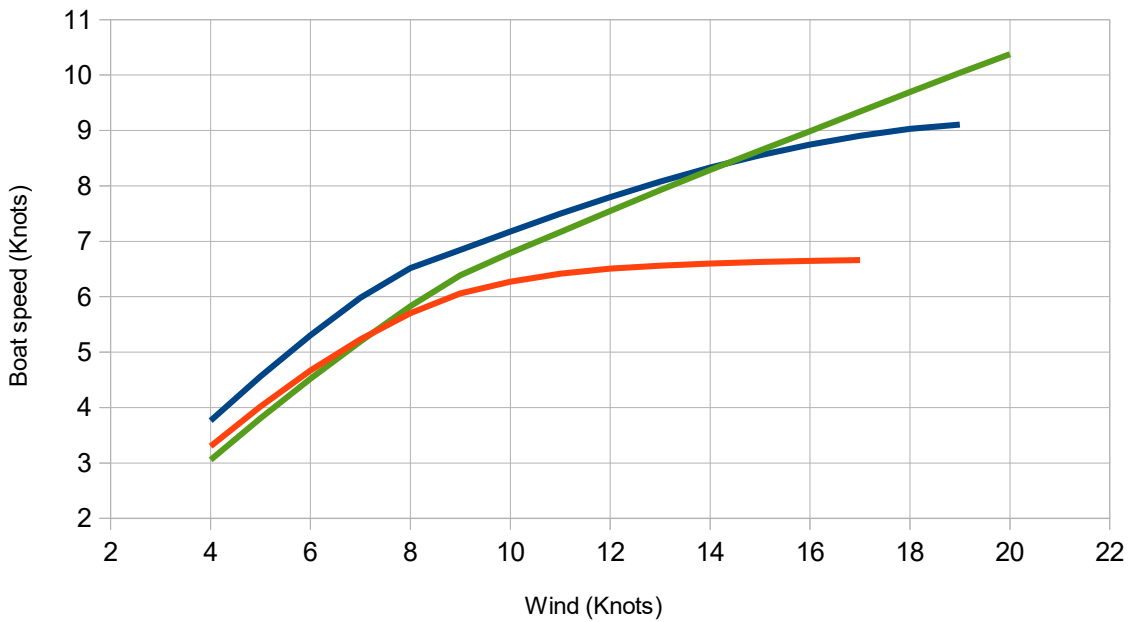

SA-VPP : Flat optimum when upwind

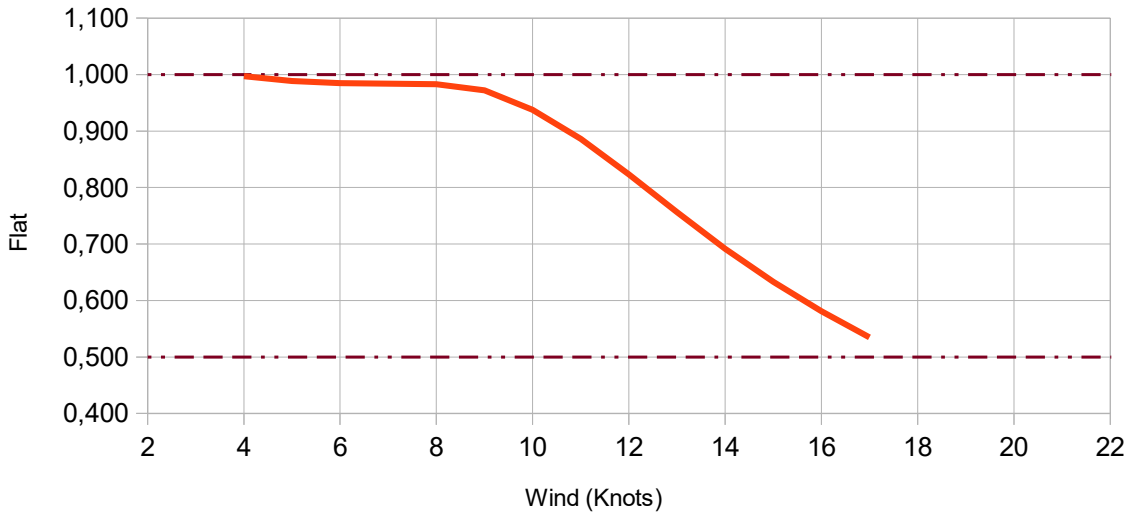

SA-VPP : Heel results

Red : Upwind ; Blue : reaching twa 90° ; Green : downwind with spi twa 135°

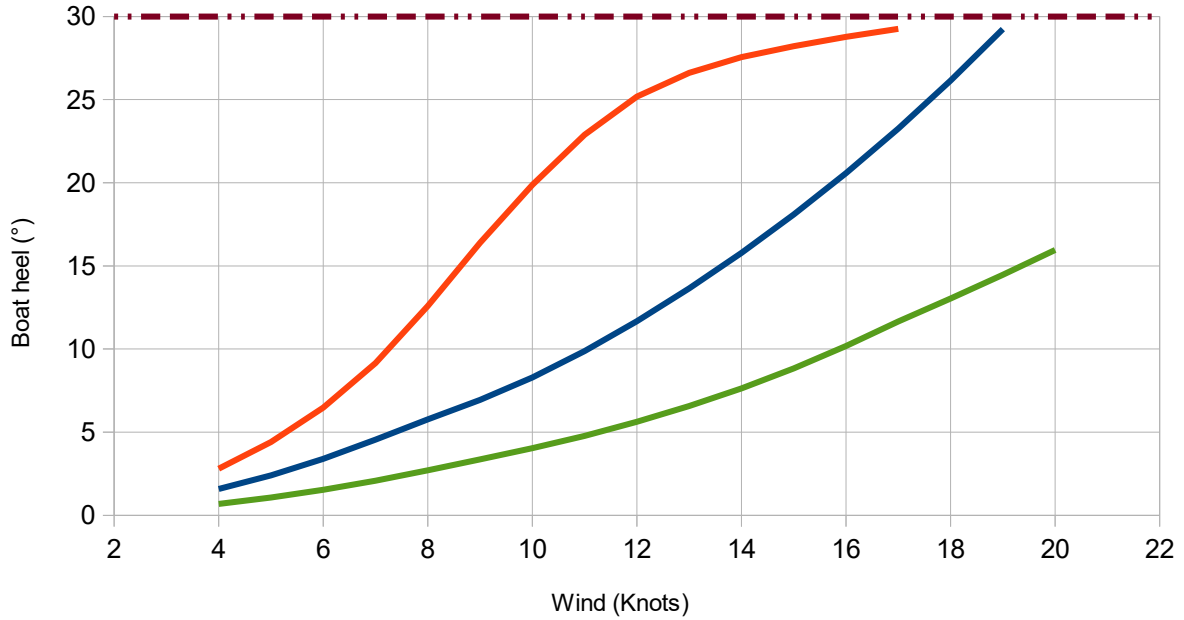

SA-VPP : Righting Moment RM versus heel angle

Black points : RM input values ; Blue : RM programmed function
Red points : SA-VPP output when upwind

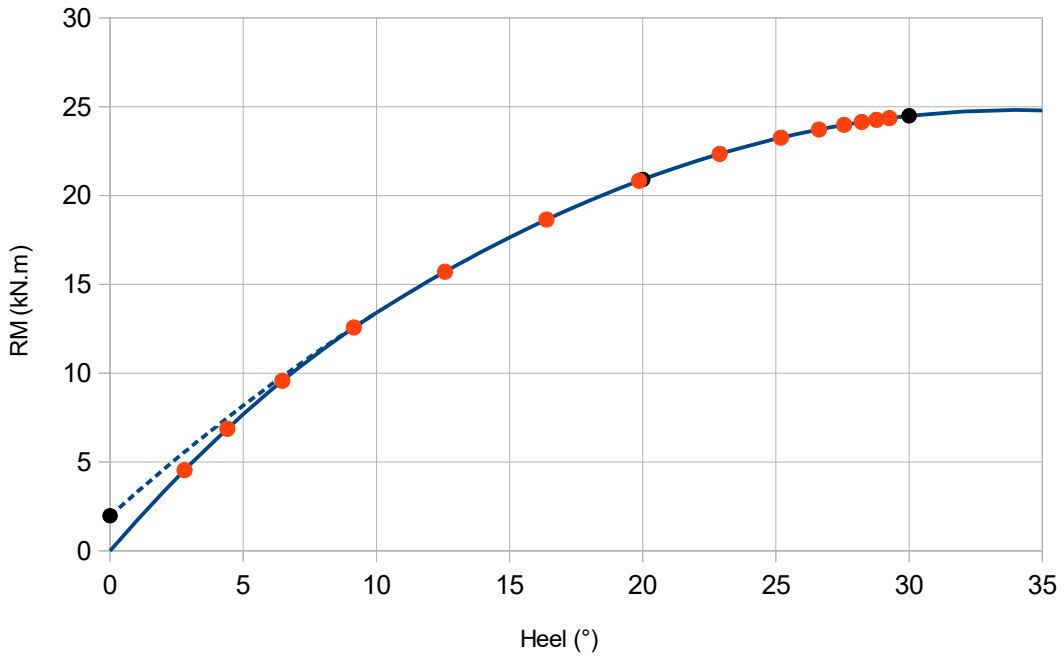

SA-VPP : Drag versus boat speed

Red : Upwind ; Blue : reaching twa 90° ; Green : downwind with spi twa 135°

